

LIFTERS

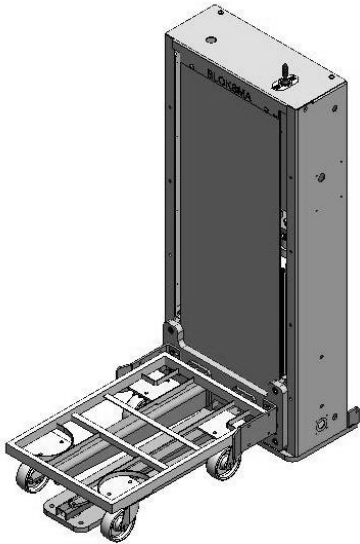

Illustrated version:
stationary lifter

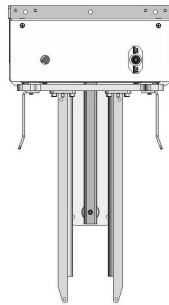

Difference between
stationary / semi-mobile / mobile
see overview MOBILITY

Pneumatic lifter HPS-F HPT-F HPM-F

Front loading –
stationary / semi-mobile / mobile
trolley lengthwise

Suitable for Bloksma trolley
BOF + BOZ (see chapter TROLLEYS)

Standard control element
Hand lever on device
(Options see Overview CONTROL
ELEMENTS)

Options:
automatic height adjustment etc.

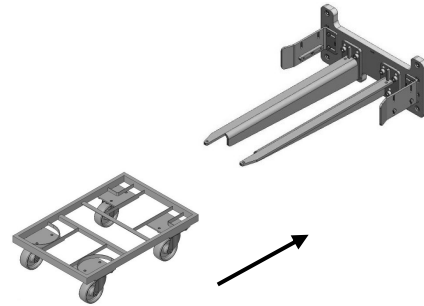

Stationary	Semi-mobile	Mobile	Load capacity	Size of trolley mm	Working height above floor level (GOK)
137003	135031	137051	200 kg	600 x 400	720 mm
137004	137100	134489	200 kg	600 x 400	920 mm
132109	137101	137053	300 kg	600 x 400	720 mm
137006	137102	137054	300 kg	600 x 400	920 mm

137009	137105	137057	500 kg	600 x 400	720 mm
137010	137106	137058	500 kg	600 x 400	920 mm

Stationary	Semi-mobile	Mobile	Load capacity	Size of trolley mm	Working height above floor level (GOK)
137011	137107	137059	200 kg	800 x 600	720 mm
137012	137108	137060	200 kg	800 x 600	920 mm
137013	137109	137061	300 kg	800 x 600	720 mm
137038	137110	137062	300 kg	800 x 600	920 mm

137017	137113	137065	500 kg	800 x 600	720 mm
202719	137114	137066	500 kg	800 x 600	920 mm

Power demand: Pneumatic 6 bar

Other models / dimensions / loads as well as control elements on request.

The appearance of the device may deviate from the plotted models.

LIFTERS

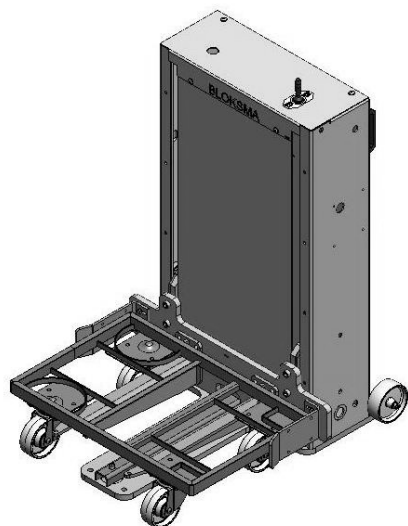

Illustrated version:
semi-mobile lifter

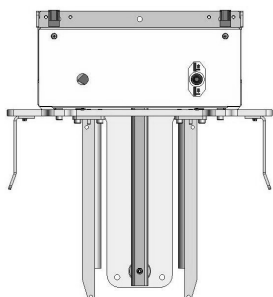

Pneumatic lifter HPS-F HPT-F HPM-F

Front loading –
stationary / semi-mobile / mobile
trolley crosswise

Suitable for Bloksma trolley
BOF + BOZ (see chapter TROLLEYS)

Standard control element
Hand lever on device
(Options see Overview CONTROL
ELEMENTS)

Options:
automatic height adjustment etc.

Difference between
stationary / semi-mobile / mobile
see overview MOBILITY

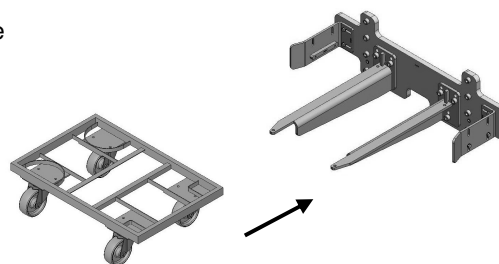

Stationary	Semi-mobile	Mobile	Load capacity	Size of trolley mm	Working height above floor level (GOK)
137027	132977	137075	200 kg	60 x 400	720 mm
137028	137124	137076	200 kg	600 x 400	920 mm
137029	137125	137077	300 kg	600 x 400	720 mm
137030	137126	137078	300 kg	600 x 400	920 mm

137033	137129	137081	500 kg	600 x 400	720 mm
137034	137130	137082	500 kg	600 x 400	920 mm

Stationary	Semi-mobile	Mobile	Load capacity	Size of trolley mm	Working height above floor level (GOK)
137035	137131	137083	200 kg	800 x 600	720 mm
137036	137132	137084	200 kg	800 x 600	920 mm
137037	137133	137085	300 kg	800 x 600	720 mm
137014	137134	137086	300 kg	800 x 600	920 mm

137041	137137	137089	500 kg	800 x 600	720 mm
137018	137138	137090	500 kg	800 x 600	920 mm

Power demand: Pneumatic 6 bar

Other models / dimensions / loads as well as control elements on request.

The appearance of the device may deviate from the plotted models.

LIFTERS

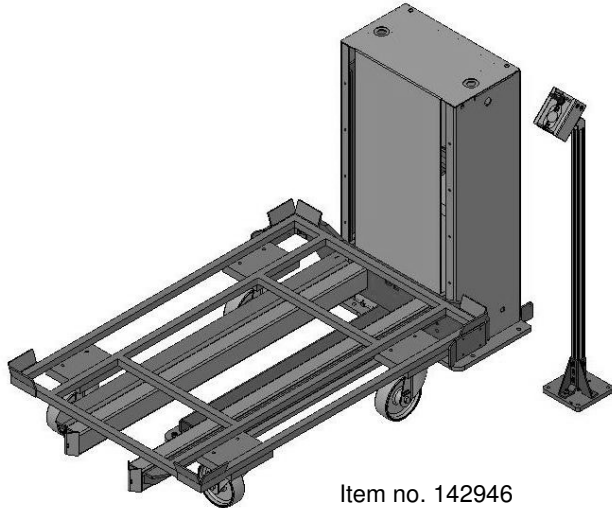

Item no. 142946
Loading with trolley

Pneumatic lifter HPS-F

Front loading –
stationary

For pallet cages or pallets of the size
1.200 x 800 mm

Suitable for ergonomic working at
assembly working stations, machines

Load capacity up to 500 kg

Standard control element
Hand lever on device
(Options see Overview CONTROL
ELEMENTS)

Options:
automatic height adjustment etc.

Item no. 146590
Loading by pallet lift truck
or forklift truck

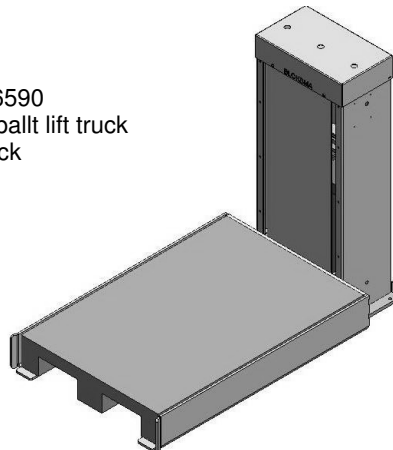

Stationary	Load capacity	Size of trolley mm	Working height above floor level (GOK)
142946	500 kg	1.200 x 800	700 mm
146590	500 kg	1.200 x 800	890 mm

Power demand: Pneumatic 6 bar

Other models / dimensions / loads as well as control elements on request.

The appearance of the device may deviate from the plotted models.